



**FITTING INSTRUCTIONS FOR AB0024BK ADVENTURE BARS**  
**BMW R1200RT 2014-**



**THIS KIT CONTAINS THE ITEMS PICTURED AND LABELLED BELOW.**  
**DO NOT PROCEED UNTIL YOU ARE SURE ALL PARTS ARE PRESENT.**

Please note that the way the kit is packed does not necessarily represent the way of mounting to the bike  
 Please note that in cases where kits are packed with rubber washers holding the components onto the bolt – *the rubber washers should be thrown away!*

THE PARTS SHOWN MAY BE REPRESENTATIVE ONLY (FOR CLARITY OF INSTRUCTIONS ONLY)

**Digital copies of these instructions are available to download from [www.rg-racing.com](http://www.rg-racing.com)**

**GENERAL TORQUE SETTINGS**

M4 BOLT = 8Nm

M5 BOLT = 12Nm

M6 BOLT = 15Nm

M8 BOLT = 20Nm

M10 BOLT = 40Nm

**TOOLS REQUIRED**

- Socket set to include 18 and 19mm sockets and wrench.
- Socket set to include T25, T50 and T55 bits and wrench.
  - Set of Allen keys to include 8mm A/F.
  - Torque wrench (up to 40Nm).

**R&G Racing**

Unit 1 Shelleys Lane, East Worldham, Alton, Hants GU34 3AQ

Tel: +44 (0)1420 89007 Fax: +44 (0)1420 87301 [www.rg-racing.com](http://www.rg-racing.com) Email: [info@rg-racing.com](mailto:info@rg-racing.com)



**In This Kit, There Should Be**

- 1x Left Hand Side Adventure Bar (CB057).
- 1x Right Hand Side Adventure Bar (CB058).
- 1x Replacement engine bar (EB086=M12x410mm long).
  - 1x Upper left hand side spacer (S0279=53mm long).
  - 1x Upper right hand side spacer (S0997=83mm long).
- 4x Lower left and right hand side spacers (S0050=7mm long).
- 4x M10x1.5x60mm long cap head bolts (lower mounts both sides).
  - 2x M12 Nyloc Nuts.
  - 2x M12 Washers.
  - 4x M10 Washers.
- 2x M12 Nut caps (NC0003).
- 4x M10 Cap head nut caps.
- 4x Tube inserts (I0047).

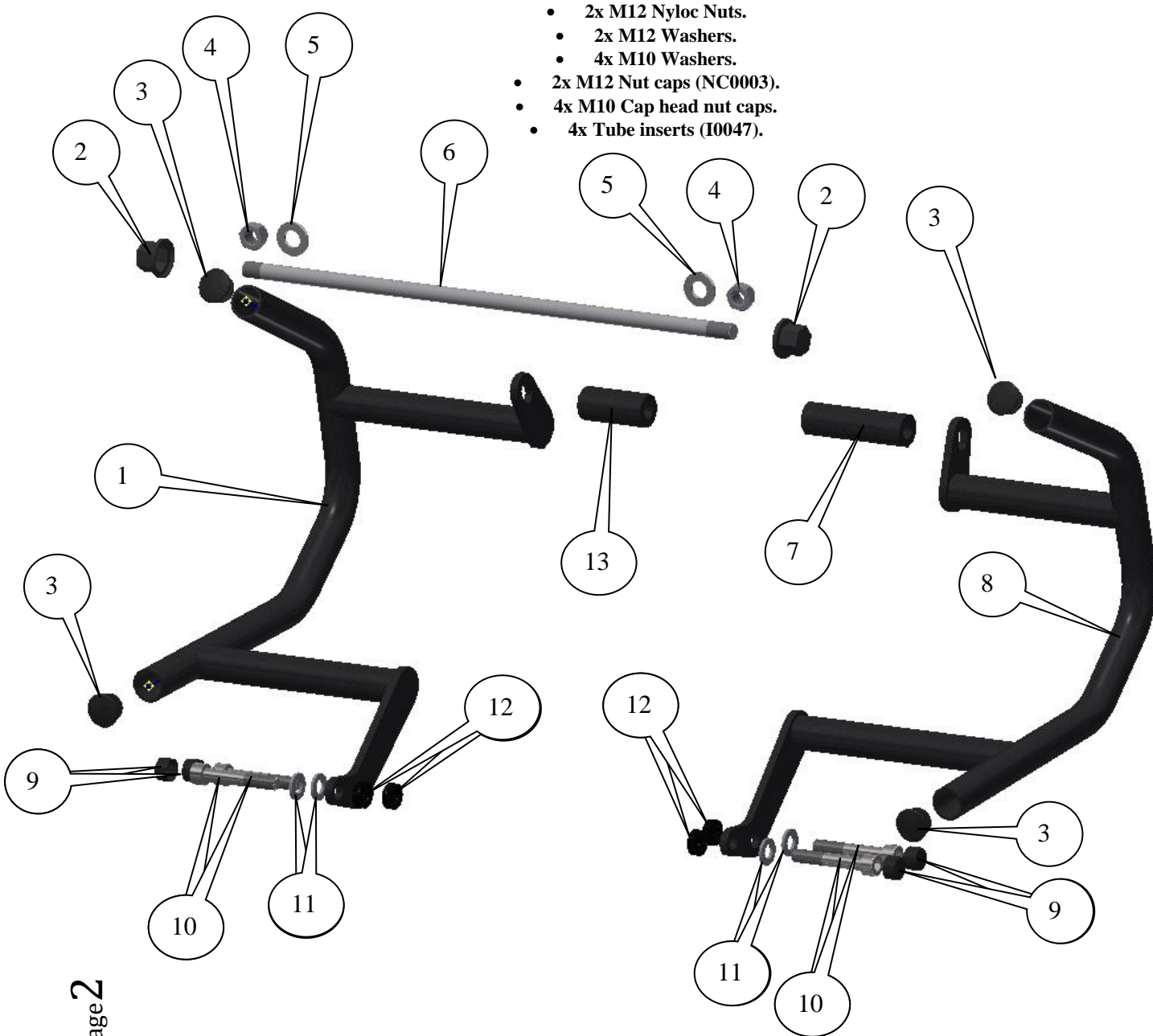



### **LEGEND**

ITEM 1 = ADVENTURE BAR LEFT-HAND SIDE (CB057=WELDED ASSEMBLY) (x1).

ITEM 2 = M12 NUT CAPS (x2).

ITEM 3 = TUBE INSERTS (I0047) (x4).

ITEM 4 = M12 NYLOC NUTS (x2).

ITEM 5 = M12 WASHERS (x2).

ITEM 6 = M12 ENGINE BAR (EB086=410mm LONG) (x1).

ITEM 7 = RIGHT HAND SIDE UPPER SPACER (S0997=83mm LONG) (x1).

ITEM 8 = ADVENTURE BAR RIGHT-HAND SIDE (CB058=WELDED ASSEMBLY) (x1).

ITEM 9 = M10 CAP HEAD BOLT RUBBER CAPS (x4).

ITEM 10 = M10x1.5x60mm LONG CAP HEAD BOLTS (x4).

ITEM 11 = M10 WASHERS (x2).

ITEM 12 = LOWER SPACERS BOTH SIDES (S0050=7mm LONG) (x4).

ITEM 13 = LEFT HAND SIDE UPPER SPACER (S0279=53mm LONG) (x1).



PICTURE 1



PICTURE 2



PICTURE 3



PICTURE 4





PICTURE 5

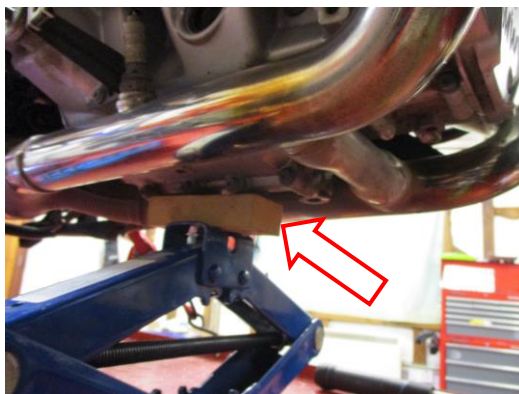

PICTURE 6



PICTURE 7



PICTURE 8



PICTURE 9

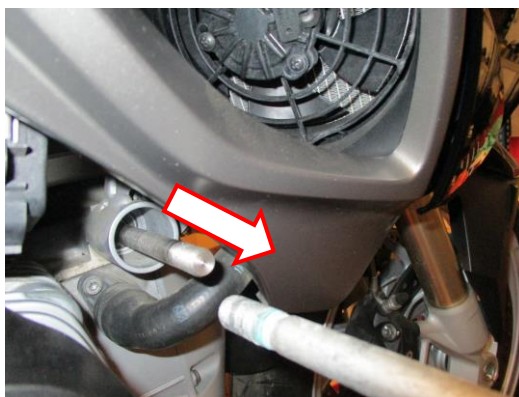

PICTURE 10

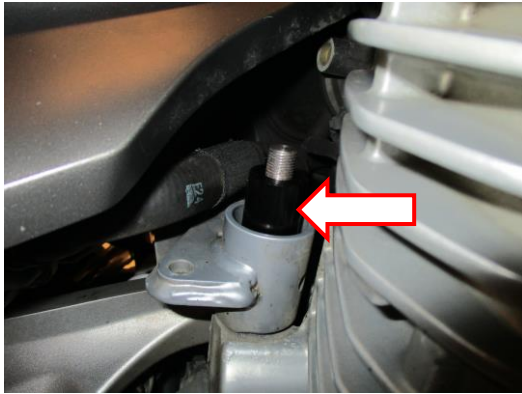

PICTURE 11

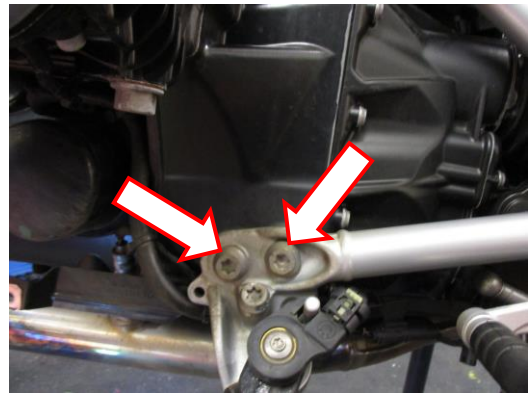

PICTURE 12



PICTURE 13



PICTURE 14



PICTURE 15

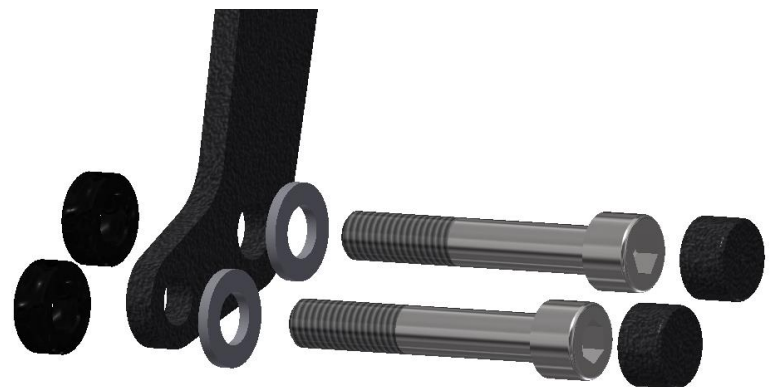

PICTURE 16

**FITTING INSTRUCTIONS**

**R&G Racing**

Unit 1 Shelleys Lane, East Worldham, Alton, Hants GU34 3AQ  
Tel: +44 (0)1420 89007 Fax: +44 (0)1420 87301 [www.rg-racing.com](http://www.rg-racing.com) Email: [info@rg-racing.com](mailto:info@rg-racing.com)



**Off side (right side as you sit on bike)**

- Remove the two lower engine fairing bolts arrowed in pictures 4 and 5, then remove the right hand side lower engine fairing.

**Near side (left side as you sit on bike)**

- Remove the three lower engine fairing bolts arrowed in pictures 1, 2 and 3, then remove the lower engine fairing.
- Remove the two lower engine fairing bolts arrowed in pictures 4 and 5, then remove the left hand side lower engine fairing.
- We suggest the engine is supported as shown in picture 6 while fitting product.
- Remove the original engine nut shown in picture 8 while stopping the engine bolt from turning as shown in picture 7.
- Use the new engine bar (item 6) to gently drift the original engine bolt out as shown in pictures 9 and 10, leave equal amounts of the bar protruding from either side of the frame.
- Place the shorter spacer (item 13) onto the exposed end of the engine bar on the left hand side as shown in picture 11.
- Remove the two bolts arrowed in picture 12.
- Place two of the M10 washers (item 11) onto two of the M10 cap head bolts (item 10) as shown in picture 13, then place these bolts through the lower mounting bracket of the left hand side adventure bar (item 1) as shown in picture 13.
- Place two of the smallest spacers (item 12) onto the exposed end of the bolts as shown in picture 13.
- Carefully offer this assembly into position so the upper mounting bracket locates onto the engine bar.
- Locate the two lower mounting bolts through the frame member and into the threaded holes as original (do not fully tighten at this stage).
- Place one of the M12 washers (item 5) and one of the M12 nyloc nuts onto the engine bar and fully engage the nut but do not tighten at this stage.

**Off side (right side as you sit on bike)**

- Place the longer spacer (item 7) onto the exposed end of the engine bar on the right hand side as shown in picture 14.
- Remove the two bolts arrowed in picture 15.
- Place two of the M10 washers (item 11) onto two of the M10 cap head bolts (item 10) as shown in picture 16, then place these bolts through the lower mounting bracket of the right hand side adventure bar (item 8) as shown in picture 16.
- Place two of the smallest spacers (item 12) onto the exposed end of the bolts as shown in picture 16.
- Carefully offer this assembly into position so the upper mounting bracket locates onto the engine bar.
- Locate the two lower mounting bolts through the frame member and into the threaded holes as original (do not fully tighten at this stage).
- Place one of the M12 washers (item 5) and one of the M12 nyloc nuts onto the engine bar and fully engage the nut but do not tighten at this stage.
- Tighten the two M12 nuts leaving equal amounts protruding through the nyloc nuts.
- Tighten the four M10 cap head bolts.
- Fit the two larger nut covers (item 2) over the two upper M12 nuts.
- Fit the four M10 bolts caps (item 9) over the lower bolts.
- Fit the four tube inserts (item 3) into the open ends of both adventure bars.



ISSUE 1 19/06/2017 (NSY)

**CONSUMER NOTICE**

The catalogue description and any exhibition of samples are only broad indications of the Products and R&G may make design changes which do not diminish their performance or visual appeal and supplying them in such state shall conform to the order. The Buyer acknowledges no representation or warranty (other than as to title) has been given or will apply to the Products other than those in R&G's order or confirmation and the Buyer confirms it has chosen the Products as being of merchantable quality and suitable for its particular purposes. Where R&G fits the Products or undertakes other services it shall exercise reasonable skill and care and rectify any fault free of charge unless the workmanship has been disturbed. The Buyer is responsible for ensuring that the warranty on the motorcycle is not affected by the fitting of the Products. On return of any defective Products R&G shall at its option either supply a replacement or refund the purchase money but shall not be liable if the Products have been modified or used or maintained otherwise than in accordance with R&G's or manufacturer's instructions and good engineering practice or if the defect arises from accident or neglect. Other than identified above and subject to R&G not limiting its liability for causing death and personal injury, it shall not be liable for indirect or consequential loss and otherwise its liability shall be limited to the amounts paid by the Buyer for the Products or the fitting or service concerned. These terms do not affect the Buyer's statutory rights.

**R&G RACING RETURNS POLICY (NON-FAULTY GOODS)**

Returns must be pre-authorized (if not pre-authorized the return will be rejected). Goods may only be returned direct to us if they were purchased direct from us (customer must prove if necessary). Otherwise to be returned to original vendor. Goods must be in re-sellable condition, in the opinion of R&G Racing. All returns are subject to a 25% restocking and handling fee (25% of the gross value exc. P&P – at the prevailing price at time of purchase). The customer must pay any and all carriage charges. No returns of discontinued products, unless within 14 days of purchase. This policy does not affect your statutory rights and does not refer to faulty goods.

**R&G Racing**

Unit 1 Shelleys Lane, East Worldham, Alton, Hants GU34 3AQ

Tel: +44 (0)1420 89007 Fax: +44 (0)1420 87301 [www.rg-racing.com](http://www.rg-racing.com) Email: [info@rg-racing.com](mailto:info@rg-racing.com)





**NOTICE DE MONTAGE POUR AB0024BK BARRES AVENTURE**  
**BMW R1200RT 2014-**



**Le kit contient les articles exposés ci-dessous, vérifier que toutes les pièces soient présentes avant de procéder au montage.**

**La façon dont le kit est emballé ne correspond pas forcément à la façon de monter les pièces sur la moto.**

**LES PARTIES PRESENTEES PEUVENT ETRE UNIQUEMENT REPRESENTATIVES (POUR LA CLARTE DES INSTRUCTIONS UNIQUEMENT)**

**Notice disponible au téléchargement sur [www.rg-racing.com](http://www.rg-racing.com)**

**VALEURS DE SERRAGE RECOMMANDEES**

M4 BOULON = 8Nm  
M5 BOULON = 12Nm  
M6 BOULON = 15Nm  
M8 BOULON = 20Nm  
M10 BOULON = 40Nm

**OUTILS REQUIS**

- Clé à cliquet + douilles de 18 et 19mm.
  - Clés T25, T50 et T55

**R&G Racing**

Unit 1 Shelleys Lane, East Worldham, Alton, Hants GU34 3AQ  
Tel: +44 (0)1420 89007 Fax: +44 (0)1420 87301 [www.rg-racing.com](http://www.rg-racing.com) Email: [info@rg-racing.com](mailto:info@rg-racing.com)





- Trousseau de clés Allen incluant une clé de 8mm.
  - Clé dynamométrique (à 40Nm).

**Ce kit doit contenir :**

- 1x Barre Aventure côté gauche (CB057).
- 1x Barre Aventure côté droit (CB058).
- 1x Barre moteur de remplacement (EB086=M12x410mm de long).
- 1x Entretoise côté supérieur gauche (S0279=53mm de long).
- 1x Entretoise côté supérieur droit (S0997=83mm de long).
- 4x Entretoises côté inférieur gauche et inférieur droit (S0050=7mm de long).
  - 4x M10x1.5x60mm Boulons (supports inférieurs des 2 côtés).
    - 2x M12 Ecrus.
    - 2x M12 Rondelles.
    - 4x M10 Rondelles.
- 2x M12 Capuchons d'écrou (NC0003).
- 4x M10 Capuchons d'écrou.
- 2x Inserts cylindriques (I0047).

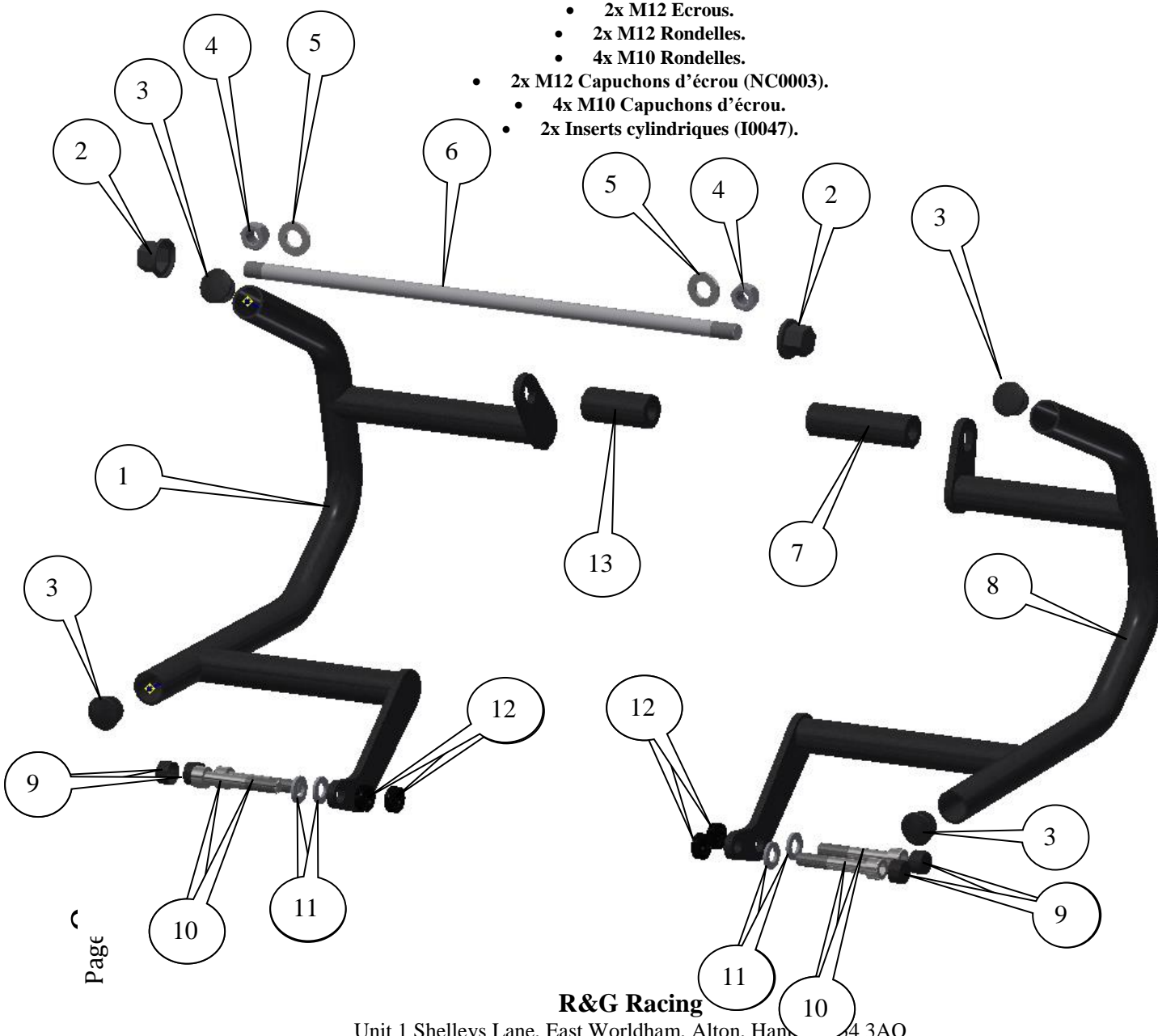

**R&G Racing**

Unit 1 Shelleys Lane, East Worldham, Alton, Hampshire GU34 3AQ

Tel: +44 (0)1420 89007 Fax: +44 (0)1420 87301 [www.rg-racing.com](http://www.rg-racing.com) Email: [info@rg-racing.com](mailto:info@rg-racing.com)



### **LEGENDE**

- ARTICLE 1 = BARRE AVENTURE CÔTÉ GAUCHE (CB057=ASSEMBLAGE SOUDÉ) (x1).  
 ARTICLE 2 = M12 CAPUCHONS D'ÉCROU (x2).  
 ARTICLE 3 = INSERTS CYLINDRIQUES (I0047) (x2).  
 ARTICLE 4 = M12 ÉCROUS (x2).  
 ARTICLE 5 = M12 RONDELLES (x2).  
 ARTICLE 6 = M12 BARRE MOTEUR (EB086=410mm DE LONG) (x1).  
 ARTICLE 7 = ENTRETOISE CÔTÉ SUPÉRIEUR DROIT (S0997=83mm DE LONG) (x1).  
 ARTICLE 8 = BARRE AVENTURE CÔTÉ DROIT (CB058=ASSEMBLAGE SOUDÉ) (x1).  
 ARTICLE 9 = M10 CAPUCHONS DE BOULON (x4).  
 ARTICLE 10 = M10x1.5x60mm BOULONS (x4).  
 ARTICLE 11 = M10 RONDELLES (x2).  
 ARTICLE 12 = ENTRETOISES INFÉRIEURES DES 2 CÔTÉS (S0050=7mm DE LONG) (x4).  
 ARTICLE 13 = ENTRETOISE CÔTÉ SUPÉRIEUR GAUCHE (S0279=53mm DE LONG) (x1).



PHOTO 1



PHOTO 2



PHOTO 3



PHOTO 4



PHOTO 5

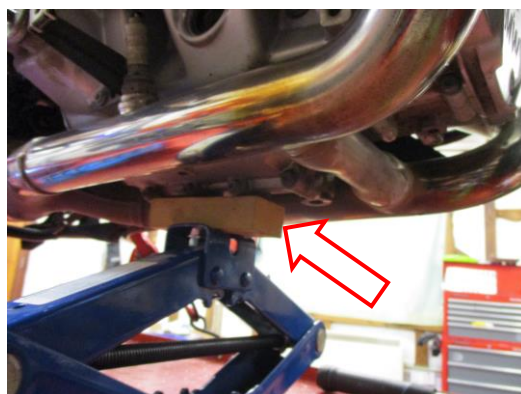

PHOTO 6



PHOTO 7



PHOTO 8



PHOTO 9

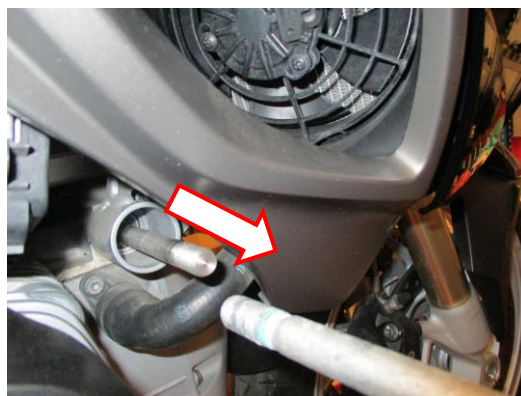

PHOTO 10





PHOTO 11

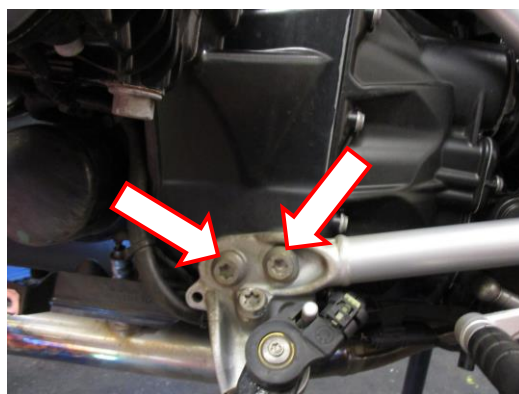

PHOTO 12



PHOTO 13



PHOTO 14

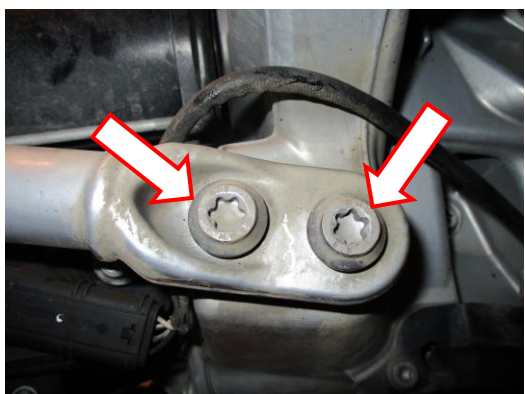

PHOTO 15

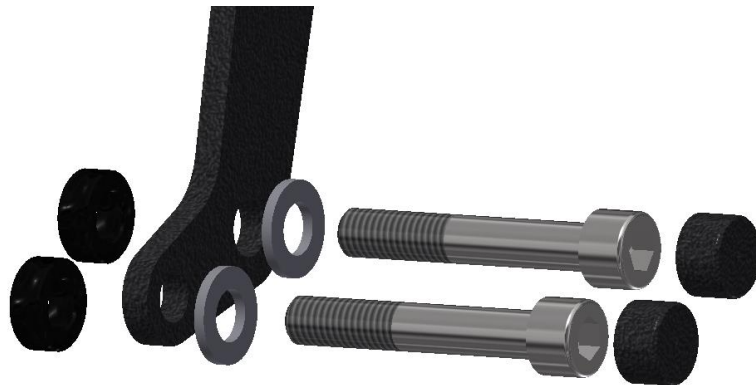

PHOTO 16





## **NOTICE DE MONTAGE**

### **Côté droit (assis sur la moto)**

- Enlever les 2 boulons de carénage moteur inférieur, voir photos 4 et 5, puis enlever le carénage moteur inférieur droit.

### **Côté gauche (assis sur la moto)**

- Enlever les boulons de carénage moteur inférieur, voir photos 1, 2 et 3, enlever le carénage moteur inférieur.
- Enlever les 2 boulons de carénage moteur inférieur, voir photos 4 et 5, puis enlever le carénage moteur inférieur gauche.
- Nous suggérons de soutenir le moteur, voir photo 6 tout en installant le produit.
- Enlever l'écrou moteur d'origine, voir photo 8 tout en empêchant le boulon moteur de tourner, voir photo 7.
- Utiliser la nouvelle barre moteur (article 6) pour dériver doucement le boulon du moteur d'origine comme sur les photos 9 et 10, en laissant dépasser la barre du cadre de chaque côté à longueur égale.
- Placer l'entretoise courte (article 13) sur l'extrémité de la barre moteur du côté gauche, voir photo 11.
- Enlever les 2 boulons indiqués sur la photo 12.
- Placer 2 rondelles M10 (article 11) sur 2 boulons M10 (article 10), voir photo 13, puis placer ces boulons dans le support de fixation inférieur de la Barre Aventure côté gauche (article 1) voir photo 13.
- Placer 2 petites entretoises (article 12) sur l'extrémité des boulons, voir photo 13.
- Monter l'ensemble en position de façon à ce que le support de fixation supérieur de place sur la barre moteur.
- Placer les 2 boulons de fixation inférieurs dans le membre du cadre et dans les trous filetés comme à l'origine (Ne pas serrer complètement pour le moment).
- Placer une des rondelles M12 (article 5) et un écrou M12 sur la barre moteur puis engager complètement l'écrou sans le serrer pour le moment.

### **Côté droit (assis sur la moto)**

- Placer la longue entretoise (article 7) sur l'extrémité de la barre moteur du côté droit, voir photo 14.
- Enlever les 2 boulons indiqués sur la photo 15.
- Placer 2 rondelles M10 (article 11) sur 2 boulons M10 (article 10), voir photo 16, puis placer ces boulons dans le support de fixation inférieur de la Barre Aventure du côté droit (article 8), voir photo 16.
- Placer 2 petites entretoises (article 12) sur l'extrémité des boulons, voir photo 16.
- Monter l'ensemble en position de façon à ce que le support de fixation supérieur se place sur la barre moteur.
- Placer les 2 boulons de fixation inférieurs dans le membre de cadre et dans les trous filetés comme à l'origine (Ne pas serrer complètement pour le moment).
- Placer une rondelle M12 (article 5) et un écrou M12 sur la barre moteur et engager l'écrou sans serrer pour le moment.
- Serrer les 2 écrous M12 en laissant dépasser des longueurs égales.
- Serrer les 4 boulons M10.
- Insérer les 2 cache écrou (article 2) sur les 2 écrous M12 supérieurs.
- Insérer les 4 cache boulons M10 (article 9) sur les boulons inférieurs.
- Insérer les 4 inserts cylindriques (article 3) dans les ouvertures des Barres Aventure.

### **R&G Racing**

Unit 1 Shelleys Lane, East Worldham, Alton, Hants GU34 3AQ

Tel: +44 (0)1420 89007 Fax: +44 (0)1420 87301 [www.rg-racing.com](http://www.rg-racing.com) Email: [info@rg-racing.com](mailto:info@rg-racing.com)



ISSUE 1 19/06/2017 (NSY)

**CONSUMER NOTICE**

The catalogue description and any exhibition of samples are only broad indications of the Products and R&G may make design changes which do not diminish their performance or visual appeal and supplying them in such state shall conform to the order. The Buyer acknowledges no representation or warranty (other than as to title) has been given or will apply to the Products other than those in R&G's order or confirmation and the Buyer confirms it has chosen the Products as being of merchantable quality and suitable for its particular purposes. Where R&G fits the Products or undertakes other services it shall exercise reasonable skill and care and rectify any fault free of charge unless the workmanship has been disturbed. The Buyer is responsible for ensuring that the warranty on the motorcycle is not affected by the fitting of the Products. On return of any defective Products R&G shall at its option either supply a replacement or refund the purchase money but shall not be liable if the Products have been modified or used or maintained otherwise than in accordance with R&G's or manufacturer's instructions and good engineering practice or if the defect arises from accident or neglect. Other than identified above and subject to R&G not limiting its liability for causing death and personal injury, it shall not be liable for indirect or consequential loss and otherwise its liability shall be limited to the amounts paid by the Buyer for the Products or the fitting or service concerned. These terms do not affect the Buyer's statutory rights.

**R&G RACING RETURNS POLICY (NON-FAULTY GOODS)**

Returns must be pre-authorized (if not pre-authorized the return will be rejected). Goods may only be returned direct to us if they were purchased direct from us (customer must prove if necessary). Otherwise to be returned to original vendor. Goods must be in re-sellable condition, in the opinion of R&G Racing. All returns are subject to a 25% restocking and handling fee (25% of the gross value exc. P&P – at the prevailing price at time of purchase). The customer must pay any and all carriage charges. No returns of discontinued products, unless within 14 days of purchase. This policy does not affect your statutory rights and does not refer to faulty goods.

**R&G Racing**

Unit 1 Shelleys Lane, East Worldham, Alton, Hants GU34 3AQ

Tel: +44 (0)1420 89007 Fax: +44 (0)1420 87301 [www.rg-racing.com](http://www.rg-racing.com) Email: [info@rg-racing.com](mailto:info@rg-racing.com)